

25. [Angles]

Skill 25.1 Measuring angles using a protractor.

MMBlue 1 2 3 3 4 4
MMGreen 1 1 2 2 3 3 4 4

Step 1: Place the protractor over the angle so that the vertex lies in the center of the protractor.

Step 2: Align one of the lines forming the angle to pass through "0" on either the inside or outside scale.

Q. Use a protractor to measure the angle shown.

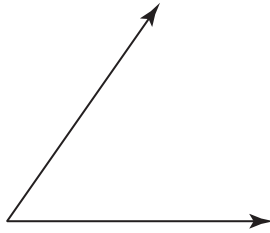

A. 55°

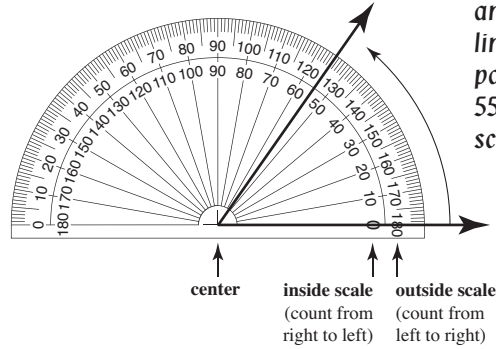

Complete steps 1 and 2. The other line of the angle passes through 55° on the inside scale.

Q. Use a protractor to measure the angle shown.

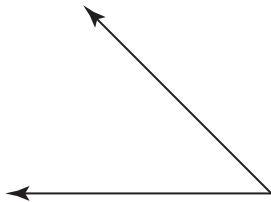

A. 45°

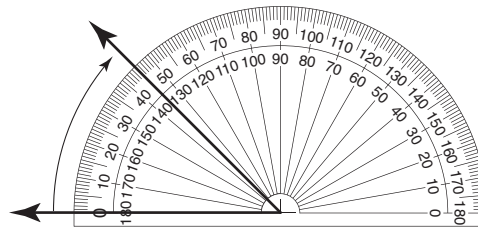

Complete steps 1 and 2. The other line of the angle passes through 45° on the outside scale.

a) Use a protractor to measure this angle.

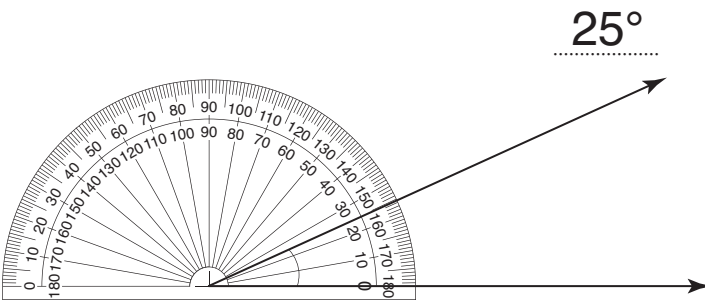

b) Use a protractor to measure this angle.

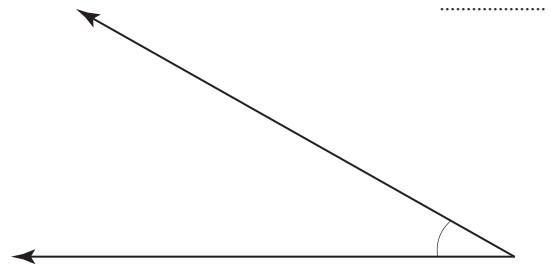

c) Use a protractor to measure this angle.

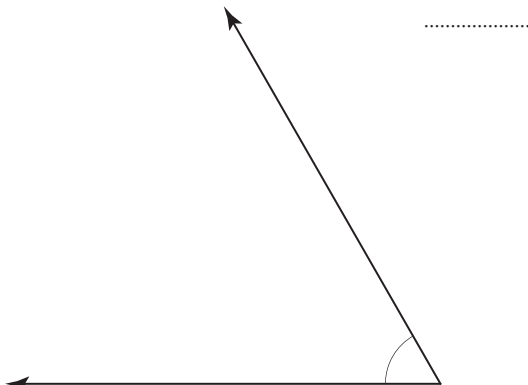

d) Use a protractor to measure this angle.

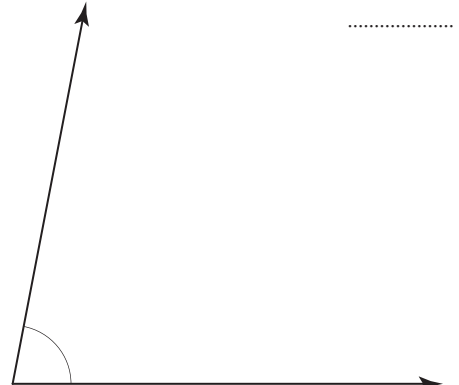

Skill 25.2 Estimating the size of an acute angle.

- Step 1: Draw an overlay of a right angle (90°).
Step 2: Divide the right angle into smaller divisions e.g. halves or thirds.

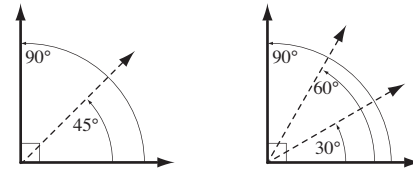

Q. Estimate the size of the angle shown.
Is it closer to 40° or 50° ?

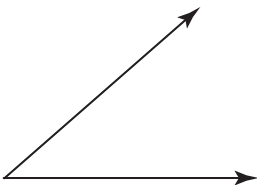

A. 40° The angle is less than 45° , so it is closer to 40° than to 50° .

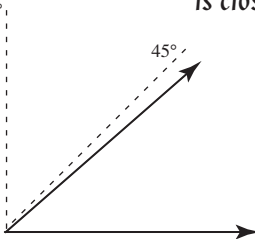

Q. Estimate the size of the angle shown.
Is it closer to 50° or 60° ?

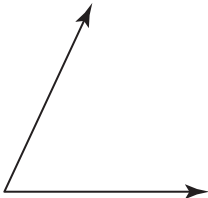

A. 60° The angle is greater than 60° , so it is closer to 60° than to 50° .

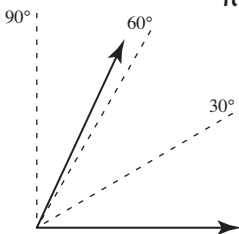

a) Estimate the size of the angle shown.
Is it closer to 50° or 70° ?

.....
50°

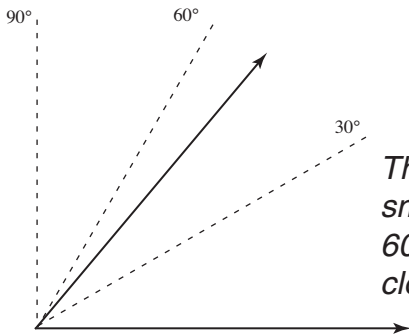

The angle is smaller than 60° , so it is closer to 50° .

b) Estimate the size of the angle shown.
Is it closer to 70° or 85° ?

.....

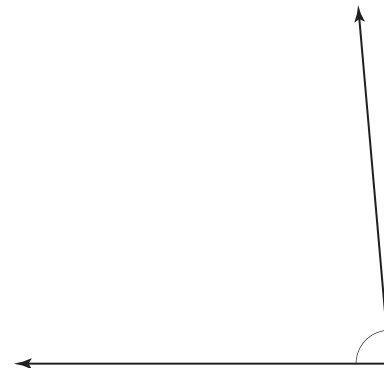

c) Estimate the size of the angle shown.
Is it closer to 45° or 60° ?

.....

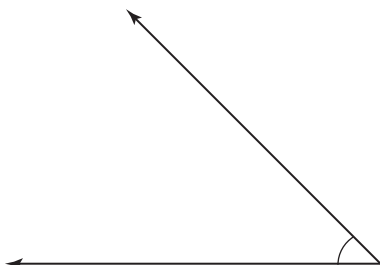

d) Estimate the size of the angle shown.
Is it closer to 30° or 45° ?

.....

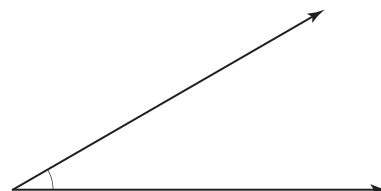

Skill 25.3 Estimating the size of an obtuse angle.

Step 1: Draw an overlay of a straight angle (180°).

Step 2: Divide the straight angle into smaller divisions e.g. quarters or sixths.

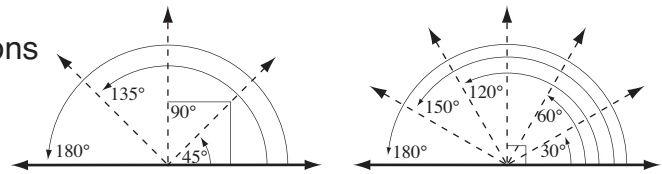

Q. Estimate the size of the angle shown.
Is it closer to 110° or 130° ?

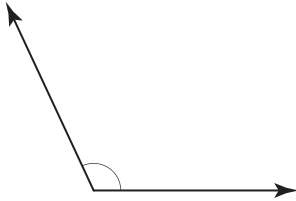

A. 110°

The angle is less than 120° , so it is closer to 110° than to 130° .

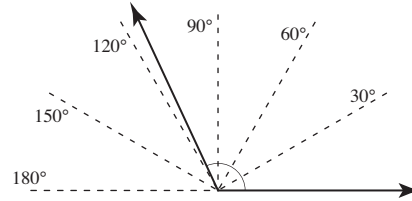

a) Estimate the size of the angle shown.
Is it closer to 105° or 120° ?

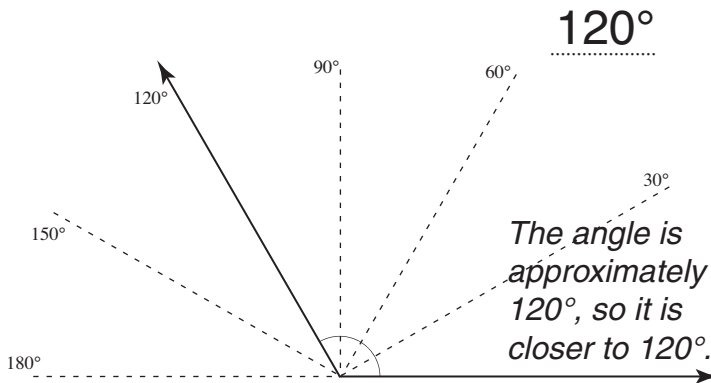

b) Estimate the size of the angle shown.
Is it closer to 135° or 120° ?

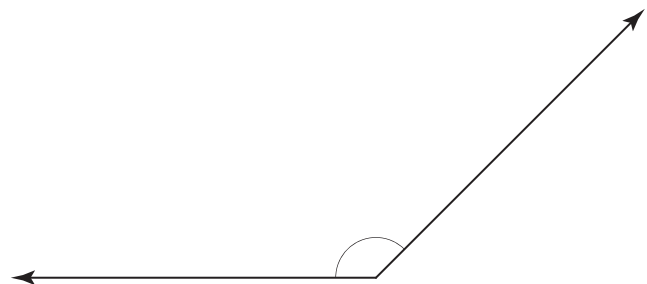

c) Estimate the size of the angle shown.
Is it closer to 180° or 170° ?

.....

d) Estimate the size of the angle shown.
Is it closer to 155° or 170° ?

.....

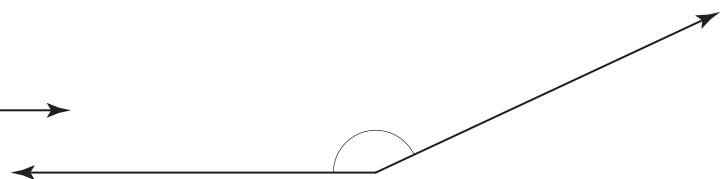

e) Estimate the size of the angle shown.
Is it closer to 95° or 110° ?

.....

f) Estimate the size of the angle shown.
Is it closer to 125° or 140° ?

.....

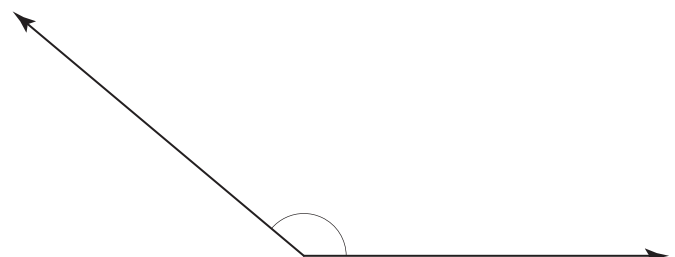
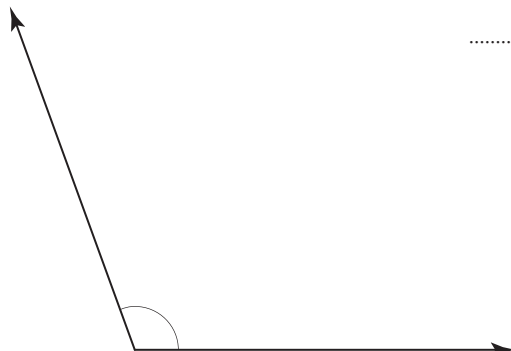

Angles making up a right angle add up to 90° .

Q. Find the value of x° .

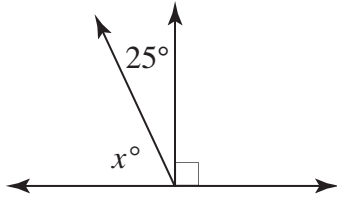

A.

$$x^\circ + 25^\circ = 90^\circ$$

$$x^\circ + 25^\circ - 25^\circ = 90^\circ - 25^\circ$$

$$x^\circ = 65^\circ$$

Q. Find the value of x° .

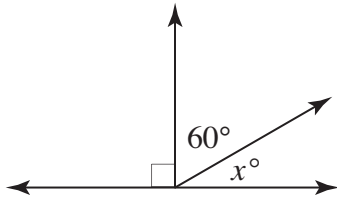

A.

$$x^\circ + 60^\circ = 90^\circ$$

$$x^\circ + 60^\circ - 60^\circ = 90^\circ - 60^\circ$$

$$x^\circ = 30^\circ$$

a) Find the value of x° .

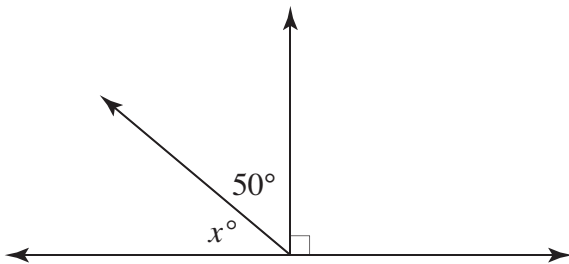

$$x^\circ + 50^\circ = 90^\circ$$

$$x^\circ + 50^\circ - 50^\circ = 90^\circ - 50^\circ$$

$$x^\circ = 40^\circ$$

b) Find the value of x° .

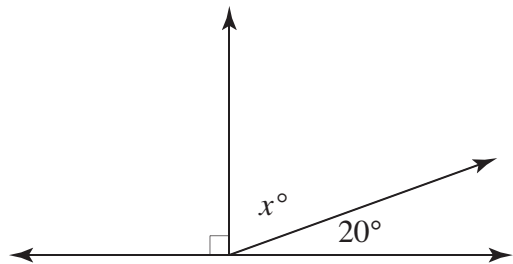

c) Find the value of x° .

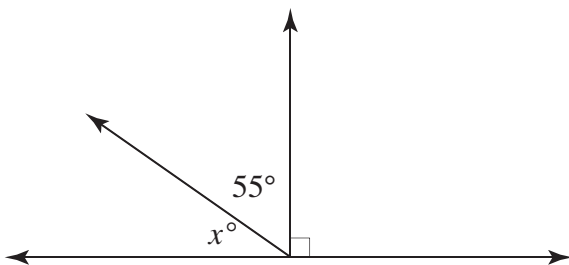

d) Find the value of x° .

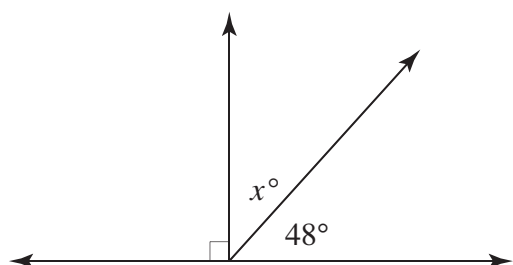

Skill 25.5 Finding the size of angles that form a straight angle.

Angles making up a straight line add up to 180° .

Q. Find the value of x° .

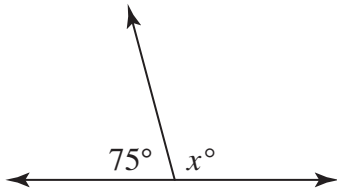

A.

$$75^\circ + x^\circ = 180^\circ$$

$$75^\circ + x^\circ - 75^\circ = 180^\circ - 75^\circ$$

$$x^\circ = 105^\circ$$

Q. Find the value of x° .

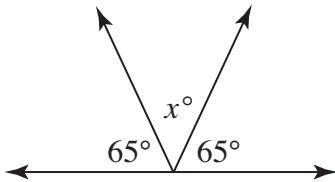

A.

$$65^\circ + x^\circ + 65^\circ = 180^\circ$$

$$x^\circ + 130^\circ = 180^\circ$$

$$x^\circ + 130^\circ - 130^\circ = 180^\circ - 130^\circ$$

$$x^\circ = 50^\circ$$

a) Find the value of x° .

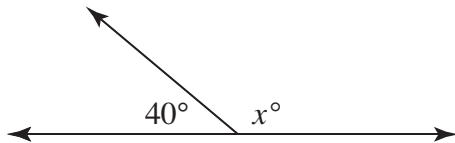

$$40^\circ + x^\circ = 180^\circ$$

$$40^\circ + x^\circ - 40^\circ = 180^\circ - 40^\circ$$

$$x^\circ = 140^\circ$$

b) Find the value of x° .

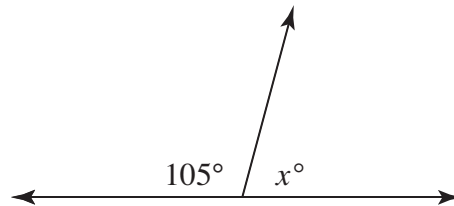

.....

.....

.....

c) Find the value of x° .

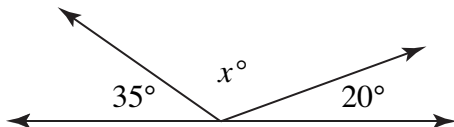

.....

.....

.....

.....

d) Find the value of x° .

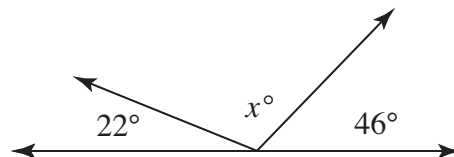

.....

.....

.....

.....

Skill 25.6 Finding the size of angles inside a triangle.

The interior angles of a triangle add to 180° .
In a right triangle, the two acute angles add to 90° .

Q. Find the value of x° .

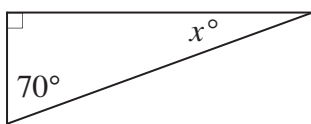

A.

$$70^\circ + x^\circ = 90^\circ$$

$$70^\circ + x^\circ - 70^\circ = 90^\circ - 70^\circ$$

$$x^\circ = 20^\circ$$

One of the acute angles of the right triangle is 70° .
The other acute angle (x°) is the difference up to 90° : $90^\circ - 70^\circ = 20^\circ$
OR
Use algebra as shown in the answer.

Q. Find the value of x° .

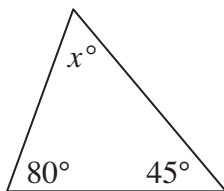

A.

$$80^\circ + 45^\circ + x^\circ = 180^\circ$$

$$125^\circ + x^\circ = 180^\circ$$

$$125^\circ + x^\circ - 125^\circ = 180^\circ - 125^\circ$$

$$x^\circ = 55^\circ$$

Add the two angles given:
 $80^\circ + 45^\circ = 125^\circ$
The third angle (x°) is the difference up to 180° : $180^\circ - 125^\circ = 55^\circ$
OR
Use algebra as shown in the answer.

a) Find the value of x° .

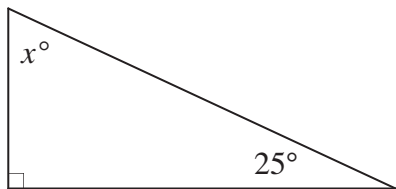

$$x^\circ + 25^\circ = 90^\circ$$

$$x^\circ + 25^\circ - 25^\circ = 90^\circ - 25^\circ$$

$$x^\circ = 65^\circ$$

b) Find the value of x° .

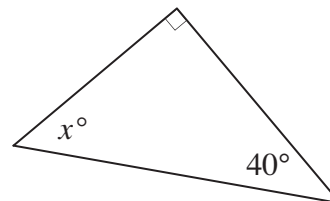

c) Find the value of x° .

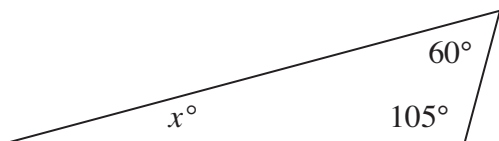

d) Find the value of x° .

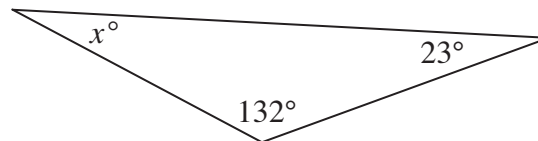

Skill 25.7 Finding the size of angles inside a quadrilateral.

The interior angles of a quadrilateral add to 360° .

Q. Find the value of x° .

[Not drawn to scale.]

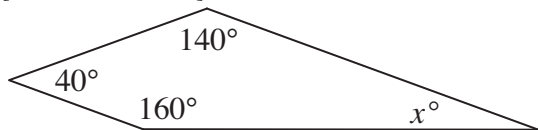

A. $160^\circ + 40^\circ + 140^\circ + x^\circ = 360^\circ$

$$340^\circ + x^\circ = 360^\circ$$

$$x^\circ + 340^\circ - 340^\circ = 360^\circ - 340^\circ$$

$$x^\circ = 20^\circ$$

Add the three angles given:

$$160^\circ + 40^\circ + 140^\circ = 340^\circ$$

The fourth angle (x°) is the difference up to 360° :

$$360^\circ - 340^\circ = 20^\circ$$

OR

Use algebra as shown.

a) Find the value of x° .

[Not drawn to scale.]

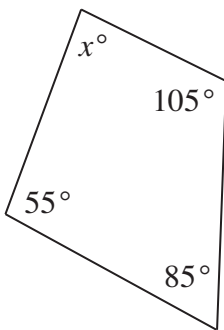

$$105^\circ + 85^\circ + 55^\circ + x^\circ = 360^\circ$$

$$245^\circ + x^\circ = 360^\circ$$

$$x^\circ + 245^\circ - 245^\circ = 360^\circ - 245^\circ$$

$$x^\circ = 115^\circ$$

b) Find the value of x° .

[Not drawn to scale.]

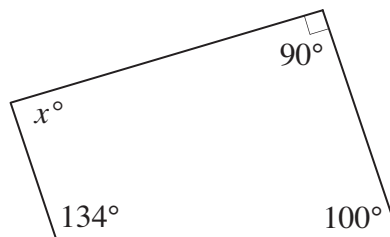

.....

.....

.....

.....

c) Find the value of x° .

[Not drawn to scale.]

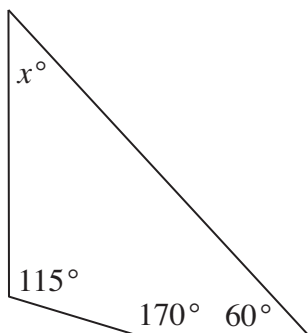

.....

.....

.....

.....

d) Find the value of x° .

[Not drawn to scale.]



.....

.....

.....

.....