

# 28. [Area / Volume]

continues on page 266

**Skill 28.1** Calculating the area of polygons by counting squares and triangles on a square grid (1).

MMBlue 1 1 2 2 3 3 4 4  
MMGreen 1 1 2 2 3 3 4 4

- Count the number of fully shaded squares on the grid.
- If necessary add on the number of half shaded squares (or triangles).
- Look for short cuts in your counting.

*Hint: To calculate the area of a rectangular shape it is possible to count the number of squares in a row and then multiply by the number of squares in a column.*

**Q.** Find the area of the rectangle.

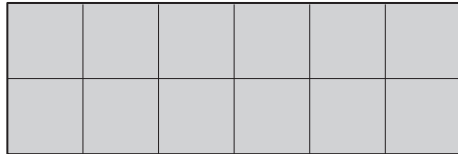

Area = 1 cm<sup>2</sup>

**A.**  $6 \times 2$   
 $= 12 \text{ cm}^2$

There are 6 squares in a row and 2 squares in a column.

1	2	3	4	5	6
2					

Area = 1 cm<sup>2</sup>

**a)** Find the area of the triangle.

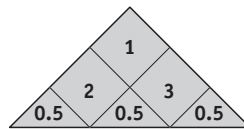
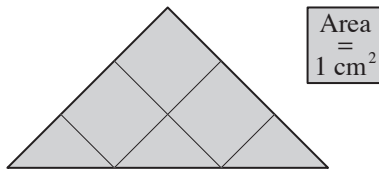

$3 + 0.5 + 0.5 + 0.5 =$  cm<sup>2</sup>

**b)** Find the area of the rectangle.

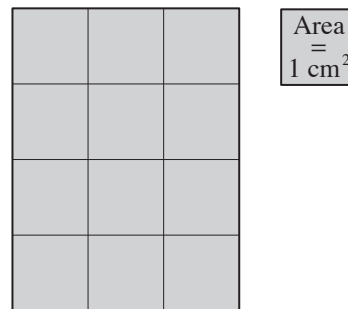

$3 \times 4 =$  cm<sup>2</sup>

**c)** Find the area of the rectangle.

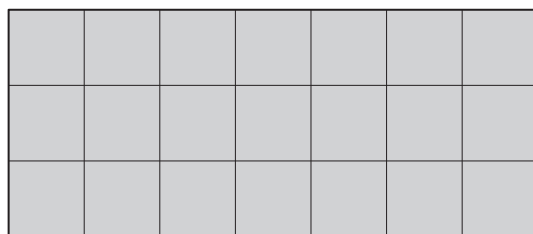

Area = 1 cm<sup>2</sup>

$=$  cm<sup>2</sup>

**d)** Find the area of the rectangle.

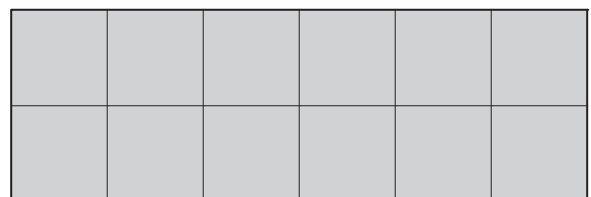

Area = 0.25 in.<sup>2</sup>

$=$  in.<sup>2</sup>

**Skill 28.1** Calculating the area of polygons by counting squares and triangles on a square grid (2).

MMBlue 1 1 2 2 3 3 4 4  
MMGreen 1 1 2 2 3 3 4 4

e) Find the area of the rectangle.

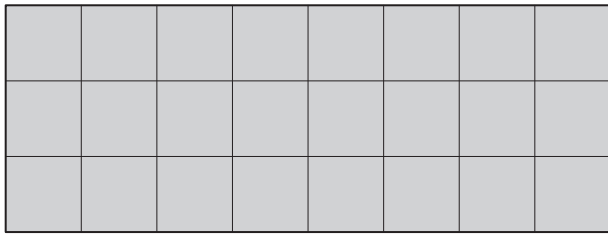

Area  
= 1 cm<sup>2</sup>

..... =

f) Find the area of the polygon.

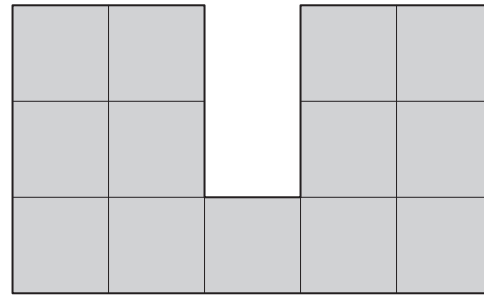

Area  
= 0.25 in.<sup>2</sup>

..... =

g) Find the area of the trapezoid.

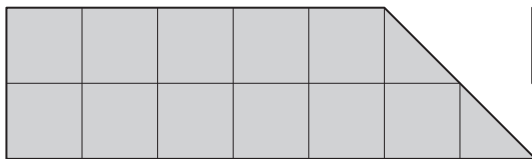

Area  
= 1 cm<sup>2</sup>

..... =

h) Find the area of the triangle.

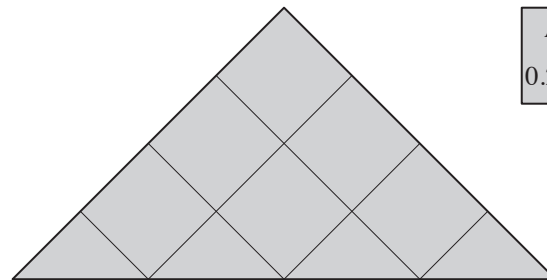

Area  
= 0.25 in.<sup>2</sup>

..... =

i) Find the area of the parallelogram.

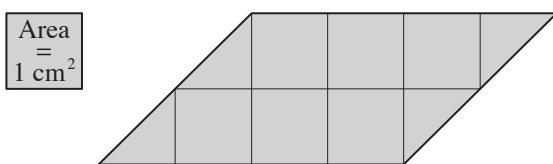

Area  
= 1 cm<sup>2</sup>

..... =

j) Find the area of the trapezoid.

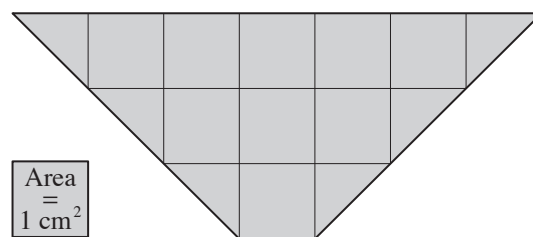

Area  
= 1 cm<sup>2</sup>

..... =

**Skill 28.2** Comparing the area of polygons on a square grid (1).

MMBlue 1 1 2 2 3 3 4 4  
MMGreen 1 1 2 2 3 3 4 4

- Break the shape up into rectangles and triangles if necessary.
- Calculate the area of any rectangle by by:
  - Counting the squares OR
  - Multiplying the number of squares in a row by the number of squares in a column.
- Calculate the area of any triangle by halving the area of the rectangle that would enclose it.
- Compare your results.

**Q.** Do the rectangle and the triangle have the same area?

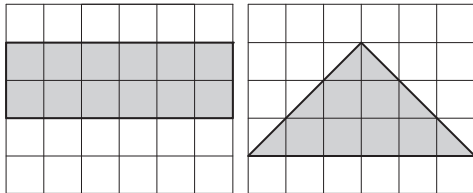

**A.**  $Area A \neq Area B$   
 $\Rightarrow$  **No**

$Area A = 6 \times 2 = 12$  sq. units

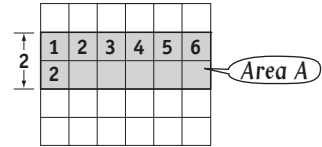

$Area B = \frac{1}{2} \times 6 \times 3$   
 $= \frac{1}{2} \times 18$   
 $= 9$  sq. units

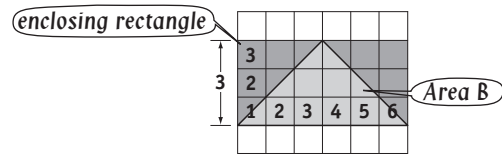

**a)** Do these rectangles have the same area?

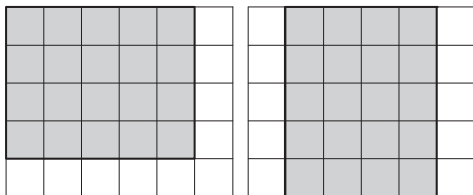

$Area A = 5 \times 4 = 20$

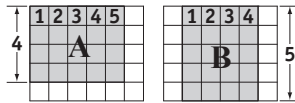

$Area B = 4 \times 5 = 20$

$\Rightarrow$  **yes**

**b)** Do these rectangles have the same area?

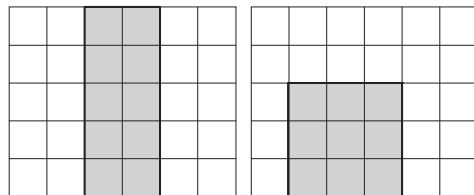

$Area A =$

$Area B =$

**c)** Do these polygons have the same area?

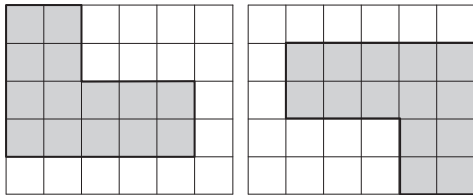

$Area A =$

$Area B =$

$\Rightarrow$

**d)** Do these triangles have the same area?

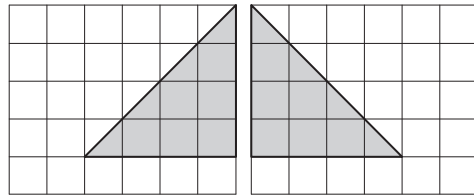

$Area A =$

$Area B =$

$\Rightarrow$

**Skill 28.2** Comparing the area of polygons on a square grid (2).

**e)** Do these triangles have the same area?

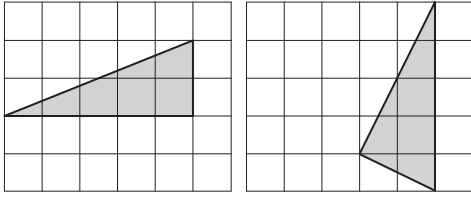

Area A = .....

Area B = ..... ⇒

**f)** Do these triangles have the same area?

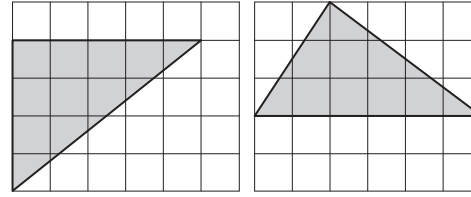

Area A = .....

Area B = ..... ⇒

**g)** Do these triangles have the same area?

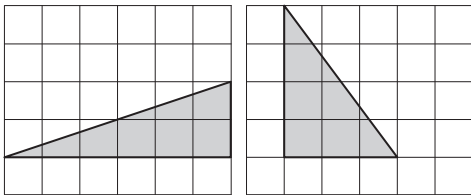

.....  
.....  
.....

**h)** Do these triangles have the same area?

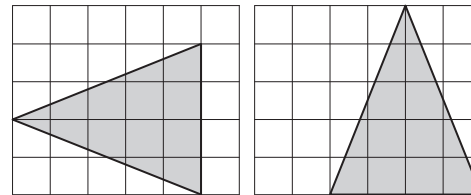

.....  
.....  
.....

**i)** Do these polygons have the same area?

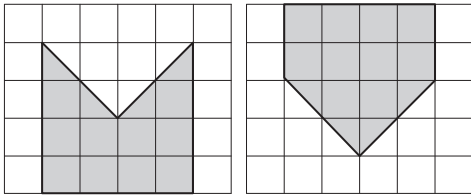

.....  
.....  
.....

**j)** Do these polygons have the same area?

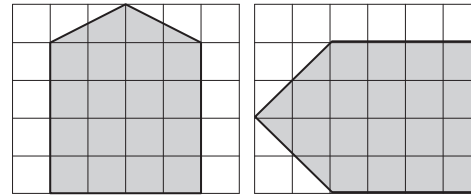

.....  
.....  
.....

**k)** Do the square and the parallelogram have the same area?

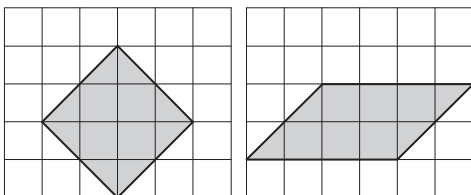

.....  
.....  
.....

**l)** Do the parallelogram and the kite have the same area?

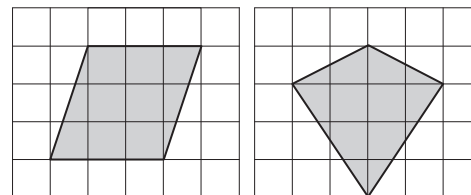

.....  
.....  
.....

### Skill 28.3 Estimating the area of irregular shapes on a square grid.

- Break the shape up into workable parts (rectangles/triangles/curved shapes).
- Calculate the area of any rectangle by:  
Counting the squares OR  
Multiplying the number of squares in a row by the number of squares in a column.
- Calculate the area of any triangle by halving the area of the rectangle that would enclose it.
- Estimate the area of any partly curved shape by making up whole squares from the shaded region.
- Add the results.

**Q.** Find the area of the shaded shape.

[Round to the nearest whole number.]

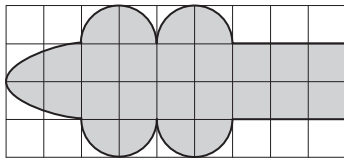

**A.**  $Area A + Area B$  Area A = 14 whole units

$$= 14 + 9$$

$$= 23 \text{ sq. units}$$

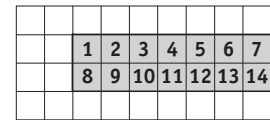

Area B = 9 units  
(made up from 12 part units)

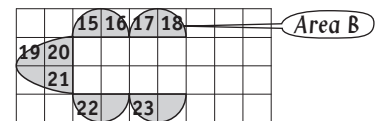

**a)** Find the area of the shaded shape.

[Round to the nearest whole number.]

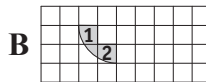
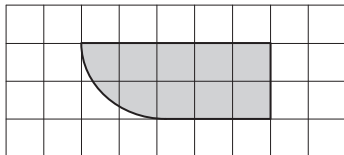

$$Area A = 7 \text{ and } Area B = 2$$

$$Area A + B = 7 + 2 = \boxed{9} \text{ sq. units}$$

**b)** Find the area of the shaded shape.

[Round to the nearest whole number.]

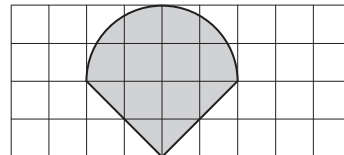

$$Area A = \quad \text{ and } Area B =$$

$$Area A + B = \quad = \boxed{\quad} \text{ sq. units}$$

**c)** Find the area of the shaded shape.

[Round to the nearest whole number.]

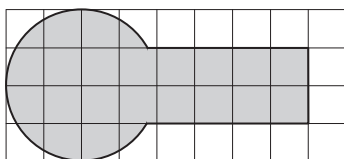

$$\quad = \boxed{\quad} \text{ sq. units}$$

**d)** Find the area of the shaded shape.

[Round to the nearest whole number.]

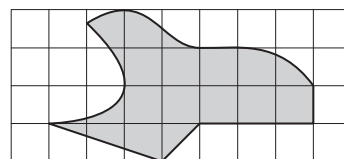

$$\quad = \boxed{\quad} \text{ sq. units}$$

**Skill 28.4** Calculating the area of squares, rectangles and parallelograms (1).

MMBlue 1 1 2 3 3 4 4  
MMGreen 1 1 2 2 3 3 4 4

- Use the appropriate formula.

**square**

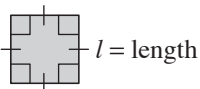

$$A = l \times l$$

$$= l^2$$

**rectangle**

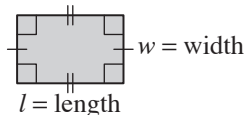

$$A = l \times w$$

$$= lw$$

**parallelogram**

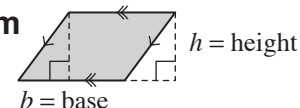

$$A = b \times h$$

$$= bh$$

- Q.** Using  $A = lw$  find the area of the rectangle.

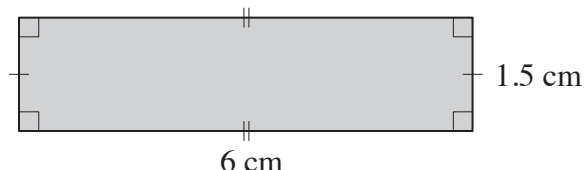

**A.**  $A = lw$  where  $l = 6$  and  $w = 1.5$

$$= 6 \times 1.5$$

$$= \mathbf{9 \text{ cm}^2}$$

- a)** Using Area = length  $\times$  width find the area of this rectangle.

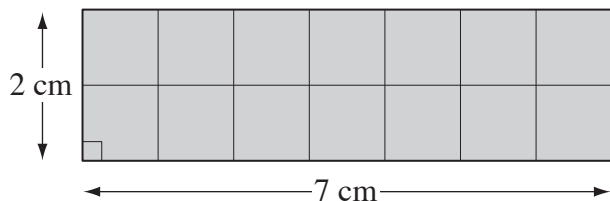

$$A = 7 \times 2 = \boxed{\text{cm}^2}$$

- b)** Using Area = length  $\times$  width find the area of this rectangle.

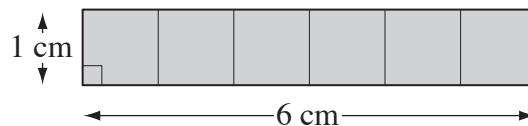

$$A = \boxed{\text{cm}^2}$$

- c)** Using Area = base  $\times$  height find the area of this parallelogram.

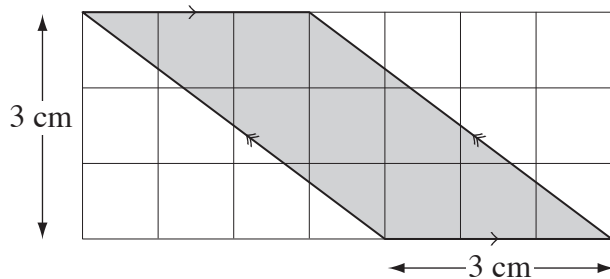

$$A = \boxed{\text{cm}^2}$$

- d)** Using Area = base  $\times$  height find the area of this parallelogram.

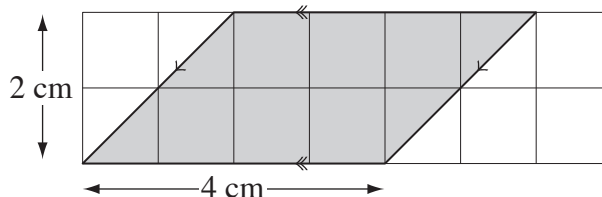

$$A = \boxed{\text{cm}^2}$$

- e)** Using Area = length  $\times$  width find the area of this rectangle.

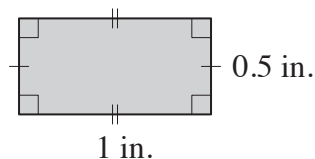

$$A = \boxed{\text{in.}^2}$$

- f)** Using  $A = lw$  find the area of the rectangle.

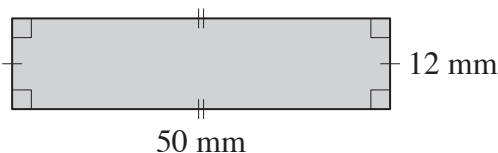

$$A = \boxed{\text{mm}^2}$$

**Skill 28.4** Calculating the area of squares, rectangles and parallelograms (2).

- g)** Using  $\text{Area} = \text{length} \times \text{length}$  find the area of the square.

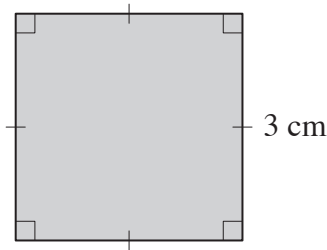

$$A = \dots = \boxed{\text{cm}^2}$$

- h)** Using  $\text{Area} = l^2$  find the area of this square.

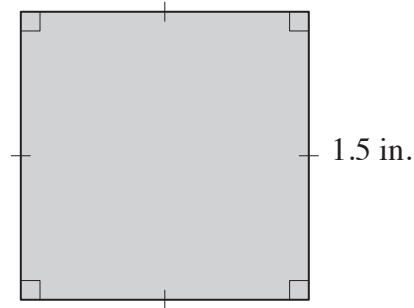

$$A = \dots = \boxed{\text{in.}^2}$$

- i)** Find the area of the square.

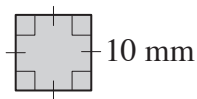

$$A = \dots = \boxed{\text{mm}^2}$$

- j)** Using  $\text{Area} = \text{base} \times \text{height}$  find the area of the parallelogram.

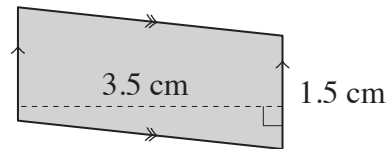

$$A = \dots = \boxed{\text{cm}^2}$$

- k)** Using  $\text{Area} = \text{base} \times \text{height}$  find the area of the parallelogram.

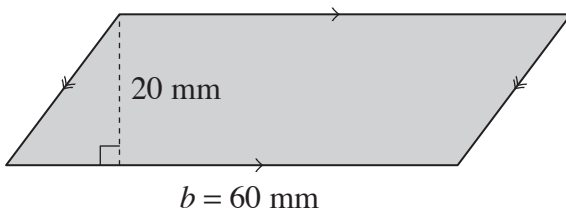

$$A = \dots = \boxed{\text{mm}^2}$$

- l)** Using  $A = lw$  find the area of the rectangle.

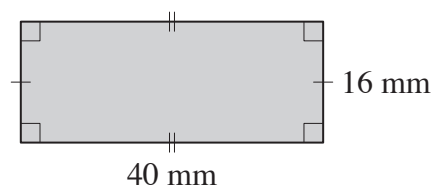

$$A = \dots = \boxed{\text{mm}^2}$$

- m)** Using  $A = bh$  find the area of the parallelogram.

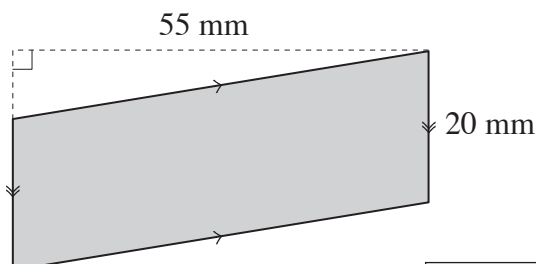

$$A = \dots = \boxed{\text{mm}^2}$$

- n)** Find the area of this parallelogram.

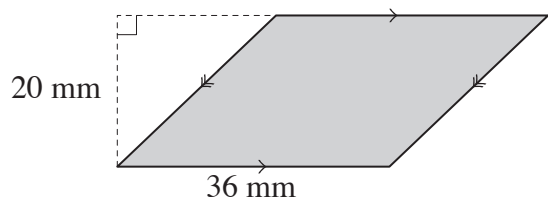

$$A = \dots = \boxed{\text{mm}^2}$$

**Skill 28.5** Calculating the area of triangles (1).

- Use the formula.

**triangle**

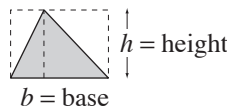

$$A = \frac{1}{2} \times b \times h$$

$$= \frac{1}{2} bh$$

**Q.** Using Area =  $\frac{1}{2} \times$  base  $\times$  height find the area of the triangle.

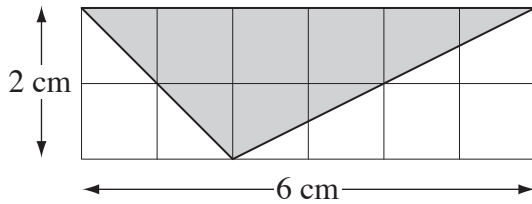

**A.**  $A = \frac{1}{2} bh$  where  $b = 6$  and  $h = 2$

$$= \frac{1}{2} \times 6 \times 2$$

$$= \frac{1}{2} \times 12$$

$$= \mathbf{6 \text{ cm}^2}$$

**a)** Using Area =  $\frac{1}{2} \times$  base  $\times$  height find the area of the triangle.

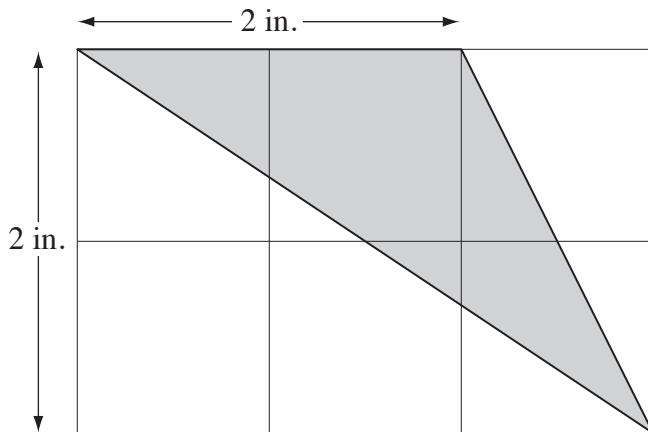

$$A = \frac{1}{2} \times 2 \times 2$$

---

$$= \frac{1}{2} \times 4 = \boxed{\text{in.}^2}$$

**b)** Using Area =  $\frac{1}{2} \times$  base  $\times$  height find the area of the triangle.

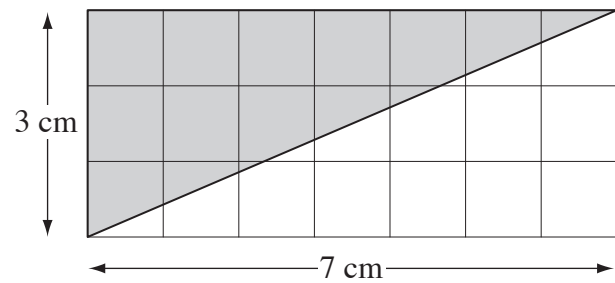

$$A =$$

---

$$= \boxed{\text{cm}^2}$$

**c)** Using Area =  $\frac{1}{2} \times$  base  $\times$  height find the area of the triangle.

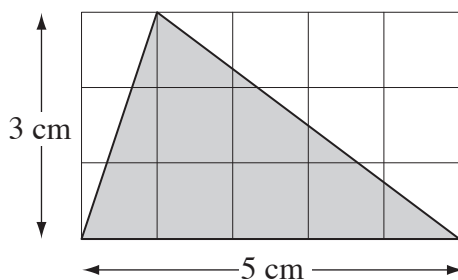

$$A =$$

---

$$= \boxed{\text{cm}^2}$$

**d)** Using  $A = \frac{1}{2} bh$  find the area of the right triangle.

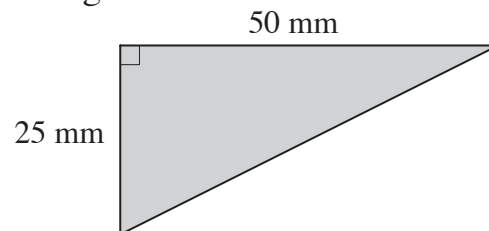

$$A =$$



---

$$= \boxed{\text{mm}^2}$$

## Skill 28.5 Calculating the area of triangles (2).

MMBlue 11 2 2 3 3 4 4  
MMGreen 11 2 2 3 3 4 4

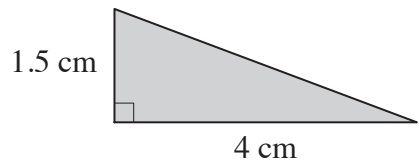
- e) Using Area =  $\frac{1}{2} \times \text{base} \times \text{height}$  find the area of the triangle.



$$A =$$

$$= \dots = \boxed{\text{cm}^2}$$

- f) Using Area =  $\frac{1}{2} bh$  find the area of the triangle.

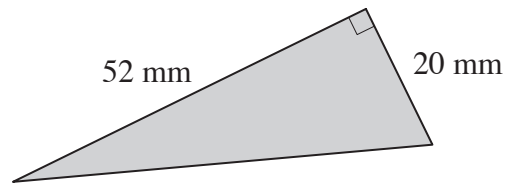

$$A =$$

$$= \dots = \boxed{\text{mm}^2}$$

- g) Using Area =  $\frac{1}{2} \times \text{base} \times \text{height}$  find the area of the triangle.

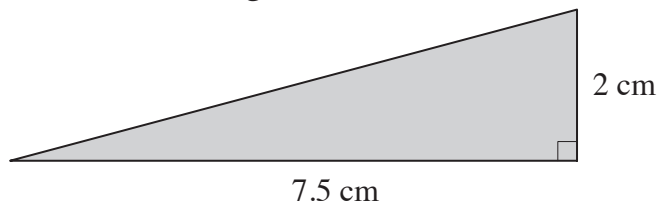

$$A =$$

$$= \dots = \boxed{\text{cm}^2}$$

- h) Using Area =  $\frac{1}{2} bh$  find the area of the triangle.

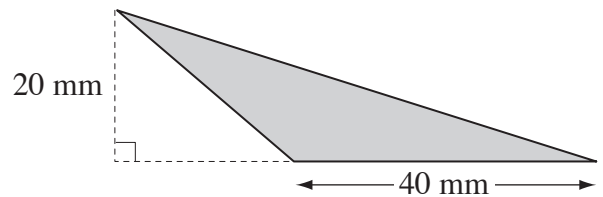

$$A =$$

$$= \dots = \boxed{\text{mm}^2}$$

- i) Using Area =  $\frac{1}{2} bh$  find the area of the triangle.

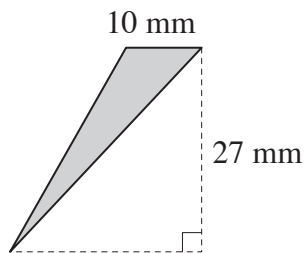

$$A =$$

$$= \dots = \boxed{\text{mm}^2}$$

- j) Using Area =  $\frac{1}{2} bh$  find the area of the triangle.

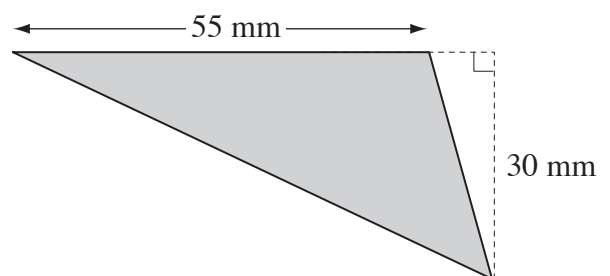

$$A =$$

$$= \dots = \boxed{\text{mm}^2}$$

**Skill 28.6** Calculating the volume of rectangular prisms by counting cubes (1).

MMBlue 1 1 2 2 3 4 4  
MMGreen 1 1 2 3 3 4 4

- Count the cubes.

*Hint: Count the cubes in one layer and then multiply the result by the total number of layers.*

**Q.** Find the volume of the rectangular prism.

**A.**  $V = 16 \times 5$   
 $= 80 \text{ cm}^3$

16 cubes in top layer  
5 layers all together

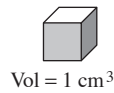
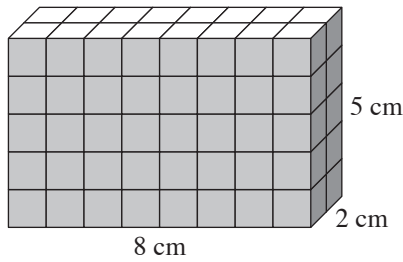

**a)** Find the volume of the rectangular prism.

**b)** If 24 boxes can fit inside these shelves, find the total volume of the boxes.

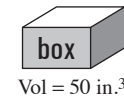
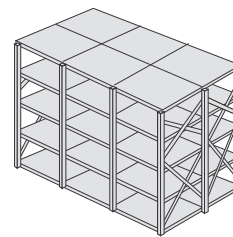
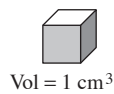
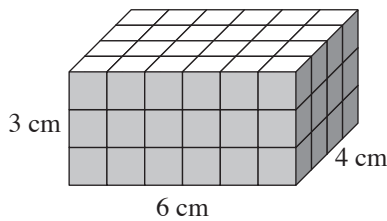

$V = 24 \times 3 = \boxed{\text{cm}^3}$

$V = \boxed{\text{in.}^3}$

**c)** Find the volume of the rectangular prism.

**d)** Find the volume of the rectangular prism.

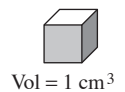
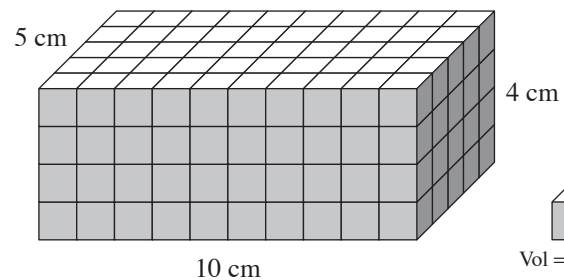
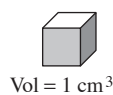
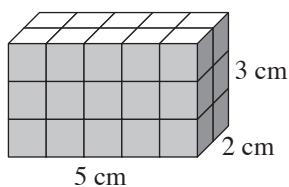

$V = \boxed{\text{cm}^3}$

$V = \boxed{\text{cm}^3}$

**e)** Find the volume of the rectangular prism.

**f)** Find the volume of the rectangular prism.

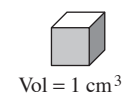
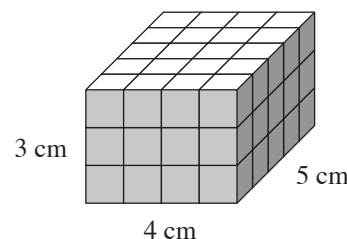
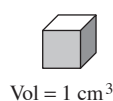
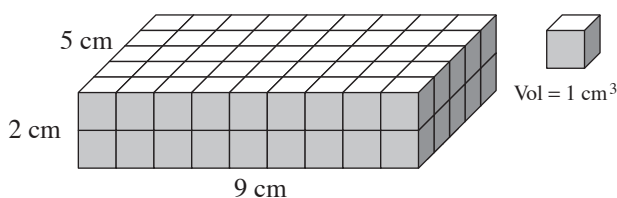

$V = \boxed{\text{cm}^3}$

$V = \boxed{\text{cm}^3}$

### Skill 28.6 Calculating the volume of rectangular prisms by counting cubes (2).

 MMBLue 11 22 3 44  
 MMGreen 11 22 3 44

- g)** Find the volume of the rectangular prism.    **h)** Find the volume of the rectangular prism.

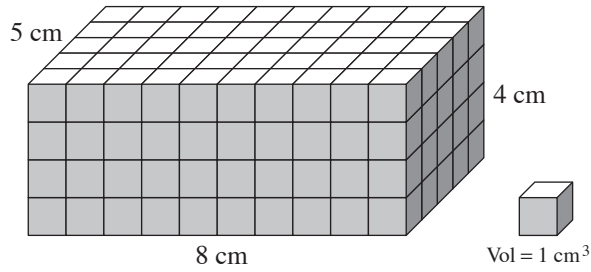

$$V = \dots = \boxed{\text{cm}^3}$$

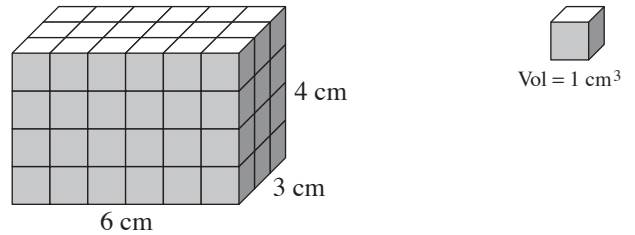

$$V = \dots = \boxed{\text{cm}^3}$$

- i)** Find the volume of the rectangular prism.    **j)** Find the volume of the rectangular prism.

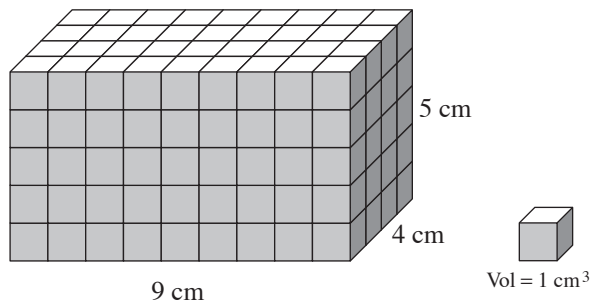

$$V = \dots = \boxed{\text{cm}^3}$$

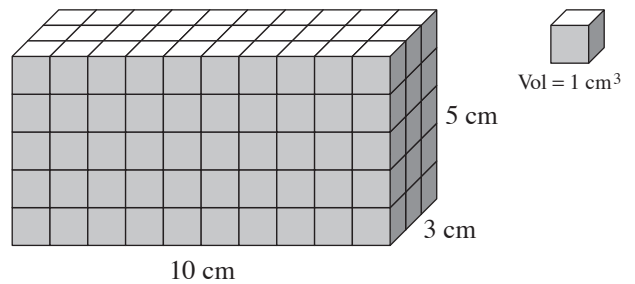

$$V = \dots = \boxed{\text{cm}^3}$$

- k)** Find the volume of the rectangular prism.    **l)** Find the volume of the rectangular prism.

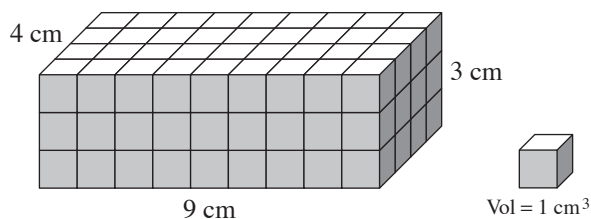

$$V = \dots = \boxed{\text{cm}^3}$$

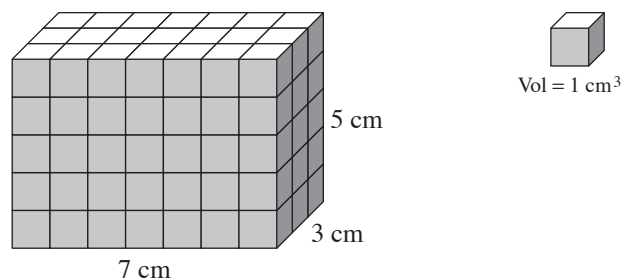

$$V = \dots = \boxed{\text{cm}^3}$$

**Skill 28.7** Calculating the volume of square and rectangular prisms (1).

MMBlue 1 1 2 2 3 3 4 4  
MMGreen 1 1 2 2 3 3 4 4

- Use the appropriate formula.

**cube**

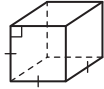

$$V = l \times l \times l$$

$$= l^3$$

**square prism**

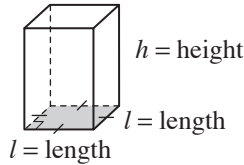

$$V = l \times l \times h$$

$$= l^2h$$

**rectangular prism**

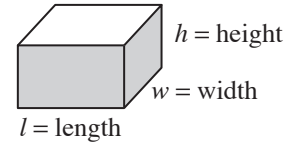

$$V = l \times w \times h$$

$$= lwh$$

- Q.** Using  $V = l^2h$  find the volume of the square prism.

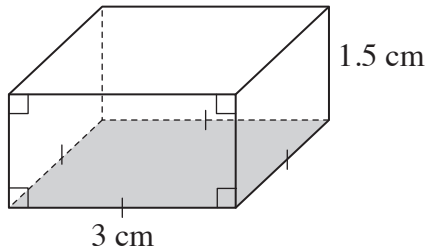

**A.**  $V = 3^2 \times 1.5$

$$= 9 \times 1.5$$

$$= \mathbf{13.5 \text{ cm}^3}$$

- a)** Using  $V = lwh$  find the volume of the rectangular prism.

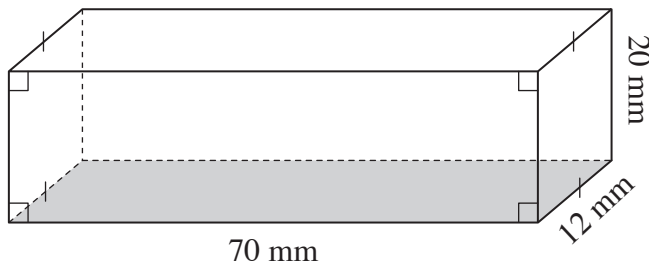

$$V = 70 \times 12 \times 20$$

$$= 840 \times 20 = \mathbf{16,800 \text{ mm}^3}$$

- b)** Using  $V = l^2h$  find the volume of the square prism.

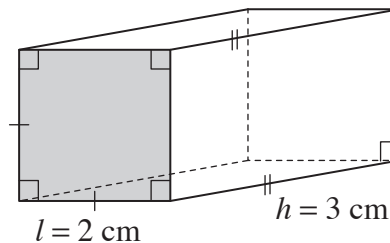

$$V =$$

$$= \quad = \mathbf{\text{cm}^3}$$

- c)** Using  $V = l^2h$  find the volume of the square prism.

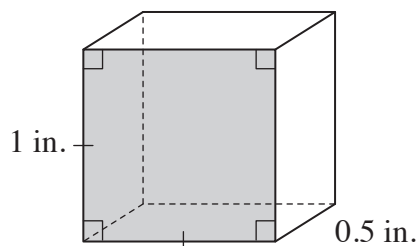

$$V =$$

$$= \quad = \mathbf{\text{in.}^3}$$

- d)** Using  $V = l^3$  find the volume of the cube.

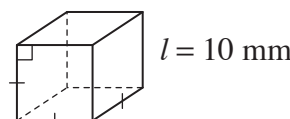

$$V =$$

$$= \quad = \mathbf{\text{mm}^3}$$

**Skill 28.7** Calculating the volume of square and rectangular prisms (2).

- e) Using  $V = lwh$  find the volume of the bank of lockers that is a rectangular prism.

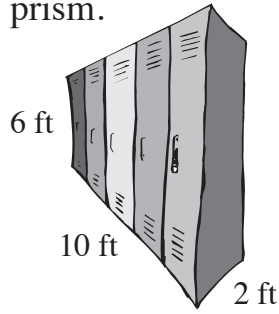

$V =$   
.....  
= =   $\text{ft}^3$

- f) Using  $V = lwh$  find the volume of the rectangular prism.

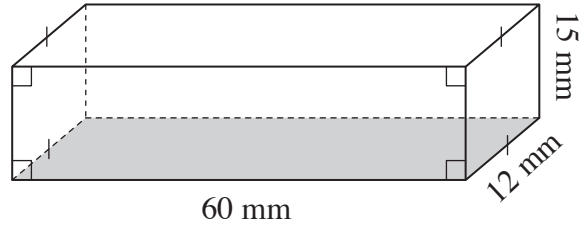

$V =$   
.....  
= =   $\text{mm}^3$

- g) Using  $V = l^3$  find the volume of the cube.

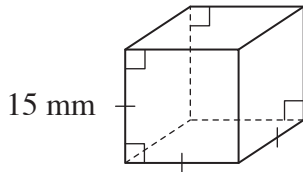

$V =$   
.....  
= =   $\text{mm}^3$

- h) Using  $V = lwh$  find the volume of the rectangular prism.

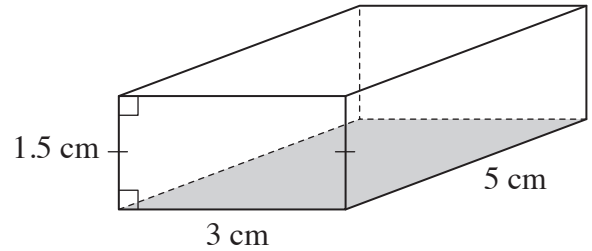

$V =$   
.....  
= =   $\text{cm}^3$

- i) Using  $V = l^2h$  find the volume of the square prism.

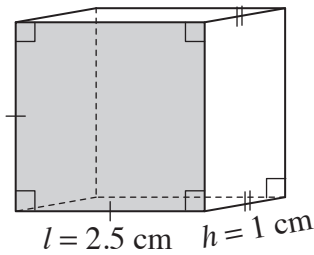

$V =$   
.....  
= =   $\text{cm}^3$

- j) Using  $V = l^2h$  find the volume of the square prism.

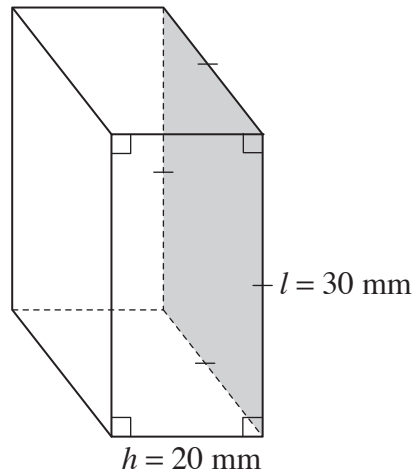

$V =$   
.....  
= =   $\text{mm}^3$

**Skill 28.8** Calculating the area of composite shapes (1).

MMBlue 1 1 2 2 3 3 4 4  
MMGreen 1 1 2 2 3 3 4 4

- Break the shape up into workable parts (rectangles/triangles).
- Calculate the area of each part. (see skill 28.4, page 270 and skill 28.6, page 274)
- Add the results.

**Q.** Find the area of the shaded polygon.

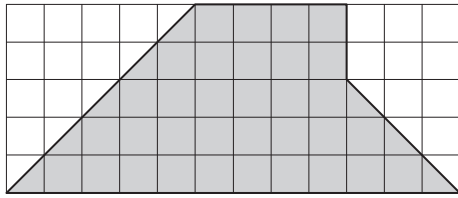

**A.**  $A_1 = lw$  where  $l = 4$  and  $w = 5$

$$= 4 \times 5$$

$$= 20$$

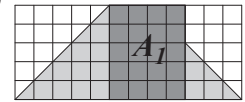

$A_2 = \frac{1}{2}bh$  where  $b = 5$  and  $h = 5$

$$= \frac{1}{2} \times 5 \times 5$$

$$= 12.5$$

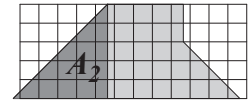

$A_3 = \frac{1}{2}bh$  where  $b = 3$  and  $h = 3$

$$= \frac{1}{2} \times 3 \times 3$$

$$= 4.5$$

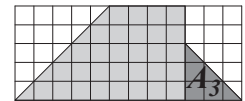

$$A = A_1 + A_2 + A_3$$

$$= 20 + 12.5 + 4.5$$

$$= 37 \text{ sq. units}$$

**a)** Find the area of the shaded polygon.

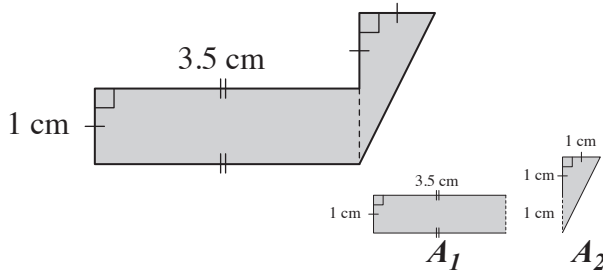

$$A_1 = 1 \times 3.5 = 3.5$$

$$A_2 = \frac{1}{2} \times 1 \times 2 = 1$$

$$A = 3.5 + 1 = \boxed{\phantom{00}} \text{ cm}^2$$

**b)** Find the area of the shaded polygon.

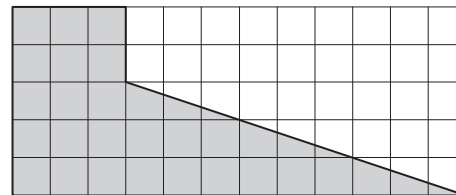

$$A_1 = \phantom{00}$$

$$A_2 = \phantom{00}$$

$$A = \phantom{00} = \boxed{\phantom{00}} \text{ sq. units}$$

**c)** Find the area of the shaded polygon.

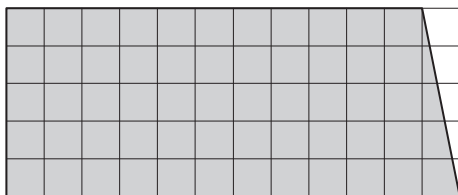

$$A_1 = \phantom{00}$$

$$A_2 = \phantom{00}$$

$$A = \phantom{00} = \boxed{\phantom{00}} \text{ sq. units}$$

**d)** Find the area of the shaded polygon.

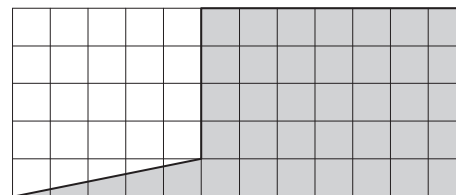

$$A_1 = \phantom{00}$$

$$A_2 = \phantom{00}$$

$$A = \phantom{00} = \boxed{\phantom{00}} \text{ sq. units}$$

**Skill 28.8** Calculating the area of composite shapes (2).

MMBlue 1 1 2 2 3 3 4 4  
MMGreen 1 1 2 2 3 3 4 4

**e)** Find the area of the shaded polygon.

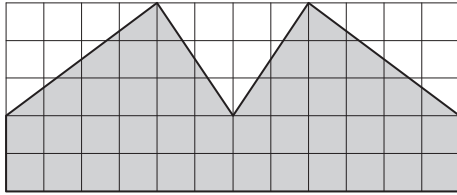

$A_1 =$  .....  $A_2 =$  .....

$A =$  ..... =

**f)** Find the area of the shaded polygon.

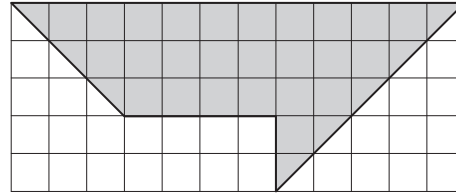

$A_1 =$  .....  $A_2 =$  .....

$A =$  ..... =

**g)** Find the area of the bowtie.

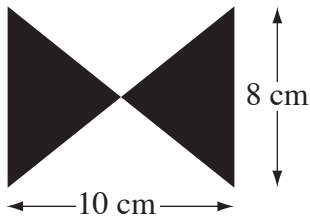

$A_1 =$  .....  $A_2 =$  .....

$A =$  ..... =

**h)** Find the area of the polygon.

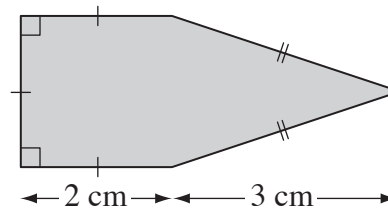

$A_1 =$  .....  $A_2 =$  .....

$A =$  ..... =

**i)** Find the area of the shaded polygon.

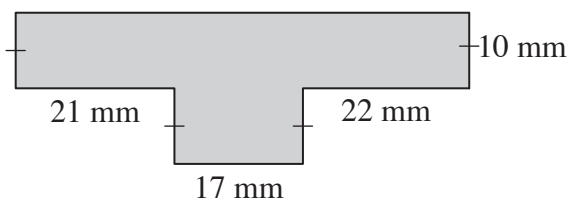

$A_1 =$  .....  $A_2 =$  .....

$A =$  ..... =

**j)** Find the area of the polygon.

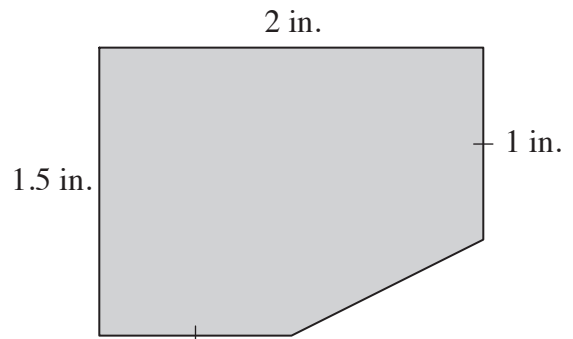

$A_1 =$  .....  $A_2 =$  .....

$A =$  ..... =

**Skill 28.9** Calculating the area of trapezoids and rhombii.

MMBlue 1 1 2 2 3 3 4 4  
MMGreen 1 1 2 2 3 3 4 4

- Use the appropriate formula.

**trapezoid**

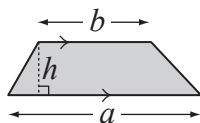

$$A = \frac{1}{2} (\text{base } a + \text{base } b) \times \text{height } h$$

$$= \frac{1}{2} (a + b)h$$

**rhombus**

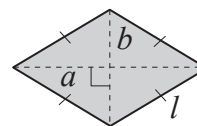

$$A = \frac{1}{2} \times \text{diagonal } a \times \text{diagonal } b$$

$$= \frac{1}{2} ab$$

**Q.** Using  $A = \frac{1}{2}(a + b)h$  find the area of the trapezoid.

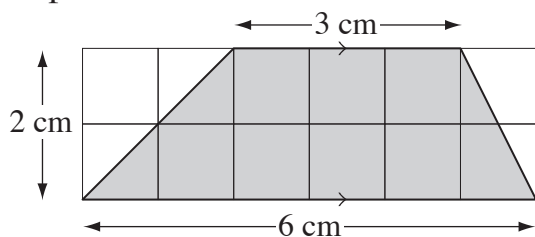

**A.**  $A = \frac{1}{2}(a + b)h$  where  $a = 3$ ,  $b = 6$  and  $h = 2$

$$= \frac{1}{2} \times (6 + 3) \times 2$$

$$= \frac{1}{2} \times 9 \times 2$$

$$= \mathbf{9 \text{ cm}^2}$$

**a)** Using  $A = \frac{1}{2}ab$  find the area of the rhombus.

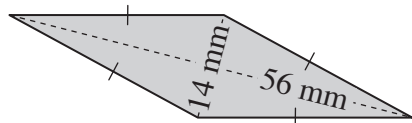

$$A = \frac{1}{2} \times 14 \times 56$$

---

$$= 7 \times 56 = \boxed{\text{mm}^2}$$

**b)** Using Area =  $\frac{1}{2}(\text{base } a + \text{base } b) \times \text{height}$  find the area of the trapezoid.

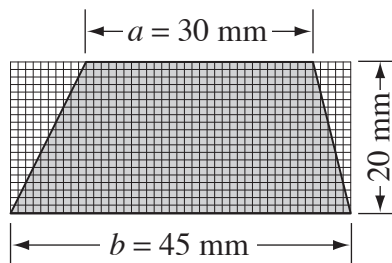

$$A =$$

---

$$= \boxed{\text{mm}^2}$$

**c)** Using  $A = \frac{1}{2}(a + b)h$  find the area of the trapezoid.

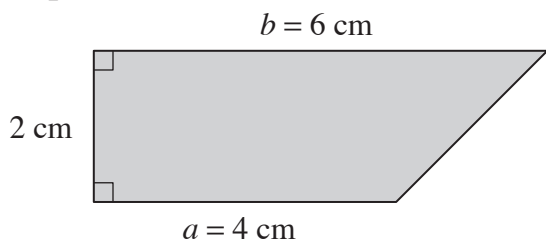

$$A =$$

---

$$= \boxed{\text{cm}^2}$$

**d)** Using Area =  $\frac{1}{2} \times \text{diagonal } a \times \text{diagonal } b$  find the area of the rhombus.

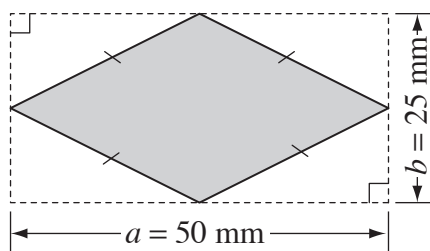

$$A =$$



---

$$= \boxed{\text{mm}^2}$$

# Skill 28.10 Calculating the area of circles and composite circular shapes.

- Use the formula.

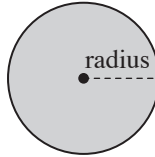
**circle**



$$A = \pi \times \text{radius} \times \text{radius}$$

$$= \pi r^2$$

where  $\pi \approx 3.14\dots$

or  $\approx \frac{22}{7}$

**Hint:** If you are given the diameter then halve to find the radius:  $r = \frac{d}{2}$

- Q.** Using  $A = \pi r^2$  and  $\pi \approx 3.14$ , find the area of the semi-circle.

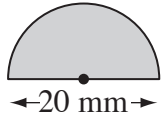

**A.** Area of circle =  $\pi r^2$  where  $d = 20$  and  $r = 10$

$$= 3.14 \times 10^2$$

$$= 3.14 \times 100$$

$$= 314$$

Area of semi-circle

$$= 314 \div 2$$

$$= 157 \text{ mm}^2$$

$r = \frac{d}{2}$

- a)** Using  $A = \pi r^2$  and  $\pi \approx 3.14$ , find the area of the shaded shape.

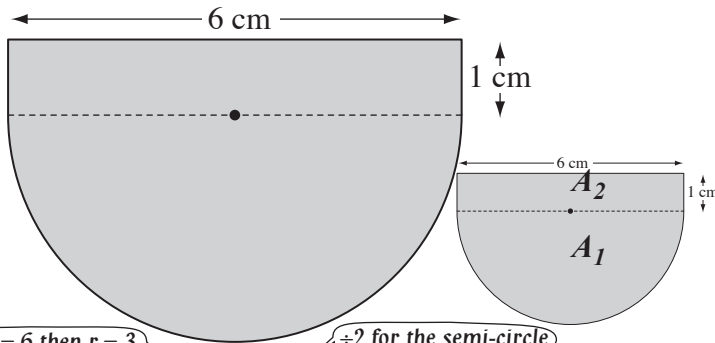

(If  $d = 6$  then  $r = 3$ )

$\div 2$  for the semi-circle

$$A_1 = 3.14 \times 3 \times 3 \div 2 = 14.13$$

$$A_2 = 6 \times 1 = 6 \text{ and using } A = A_1 + A_2$$

$$A = 14.13 + 6 = \boxed{\text{cm}^2}$$

- b)** Using  $A = \pi r^2$  and  $\pi \approx \frac{22}{7}$ , find the area of the circle.

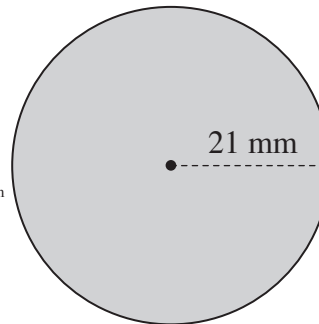

$$A =$$

$$= \boxed{\text{mm}^2}$$

- c)** Using  $A = \pi r^2$  and  $\pi \approx 3.14$ , find the area of the semi-circle.

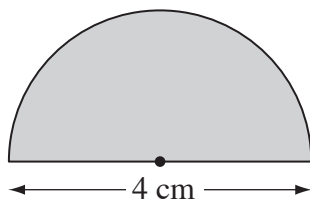

$$A =$$

$$= \boxed{\text{cm}^2}$$

- d)** Using  $A = \pi r^2$  and  $\pi \approx 3.14$ , find the area of the shaded shape.

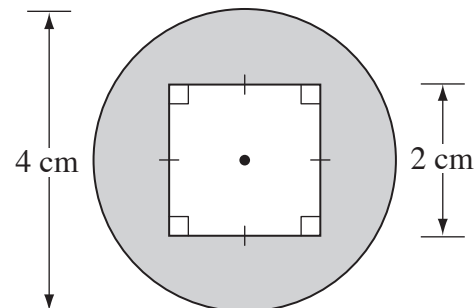

$$A_1 =$$

$$A_2 =$$

$$A = \boxed{\text{cm}^2}$$

**Skill 28.11** Calculating the volume of any prism.

- Use the general formula.

**prism**

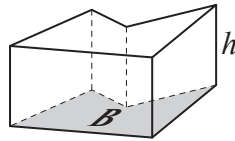

$$V = \text{Area of base} \times \text{height of prism}$$

$$= Bh$$

- Q.** Using  $V = Bh$  find the volume of the prism.

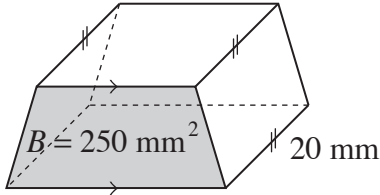

**A.**  $A = Bh$  where  $B = 250$  and  $h = 20$

$$= 250 \times 20$$

$$= \mathbf{5000 \text{ mm}^3}$$

- a)** Using  $V = Bh$  find the volume of the triangular prism.

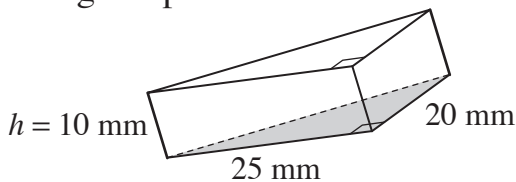

$$B = \frac{1}{2} \times 25 \times 20 = 250$$

$$V = 250 \times 10 = \boxed{\text{mm}^3}$$

- b)** Using Volume = area of the base  $\times$  height of the prism, find the volume of the pentagonal prism.

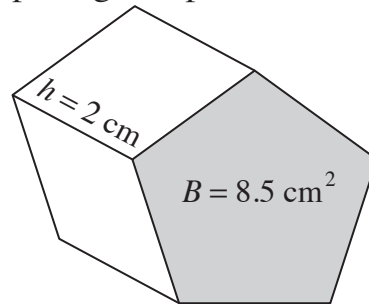

$$V = \boxed{\text{cm}^3}$$

- c)** Using  $V = Bh$  find the volume of the hexagonal prism.

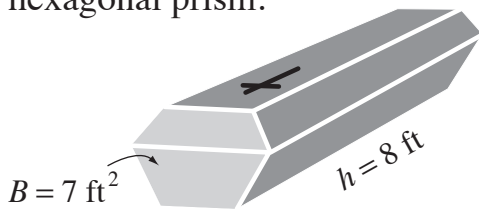

$$V = \boxed{\text{ft}^3}$$

- d)** Using  $V = Bh$  find the volume of the prism.

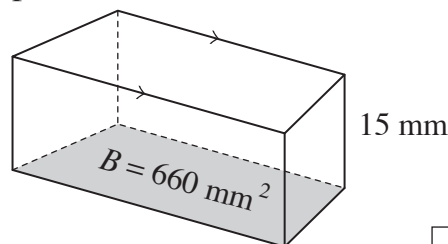

$$V = \boxed{\text{mm}^3}$$

- e)** Using  $V = Bh$  find the volume of the triangular prism.

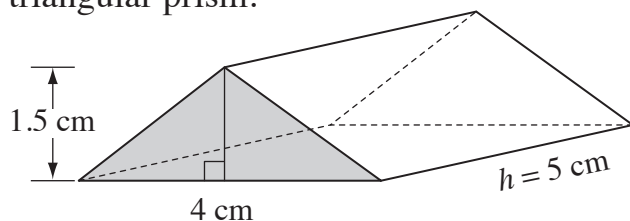

$$B =$$

$$V = \boxed{\text{cm}^3}$$

- f)** Using  $V = Bh$  find the volume of the triangular prism.

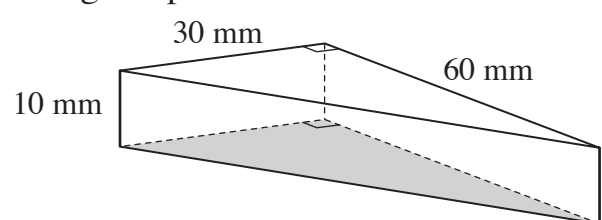

$$B =$$

$$V = \boxed{\text{mm}^3}$$